

The Role of Rock Engineering in Developing a Deep Geological Repository in Sedimentary Rocks

Rodney S. Read

RSRead Consulting Inc., Okotoks, Alberta, Canada

Kenneth Birch

Nuclear Waste Management Organization, Toronto, Ontario, Canada

ABSTRACT: Both crystalline and sedimentary rocks are being considered to host a deep geological repository (DGR) for nuclear fuel waste in Canada. In the past several decades, considerable research has been conducted around the world to better understand geomechanical processes associated with development and long-term performance of a DGR. The Nuclear Waste Management Organization's (NWMO's) technical research and development program is examining a number of potentially suitable rock formations to support implementation of Adaptive Phased Management, Canada's approach for long-term management of nuclear fuel waste. Rock engineering will play an important role in siting, design, and construction of a DGR for nuclear fuel waste. Post-construction activities such as excavation maintenance, monitoring, decommissioning, and closure will also involve rock engineering. The type of host rock selected for a DGR will influence the scope of rock engineering activities and related research requirements. This paper outlines key rock engineering aspects to be considered in developing a DGR in sedimentary rock.

1 INTRODUCTION

Rock engineering involves the application of rock mechanics and engineering geology principles to resolve engineering issues associated with structures constructed in, or composed of, rock and possibly other geomaterials. One of the more challenging rock engineering issues of our time is the safe long-term management of used nuclear fuel from nuclear reactors.

Considerable research has been conducted in Canada on concepts to contain and isolate used nuclear fuel in crystalline rock, focused largely on granitic rock of the Canadian Shield. Other countries are considering crystalline rock, volcanic rock, sedimentary rock, and salt as possible host media for a deep geological repository (DGR). A review of used fuel isolation concepts and management strategies (NWMO 2005) recommended that both crystalline rock and sedimentary rock should be considered as potential host media for a DGR in Canada.

Comprehensive work related to rock engineering for DGR concepts in crystalline rock has been completed (e.g. Andersson et al. 2000, Martin et al. 2001, Read & Chandler 2002, Read 2008). This paper focuses primarily on identifying unique rock engineering aspects related to a DGR in sedimentary rock. Relevant background information is included to clarify the context of the engineering issues. Additional details of this study are provided in Read (2008).

2 LONG-TERM NUCLEAR FUEL WASTE MANAGEMENT IN CANADA

2.1 *Adaptive Phased Management*

In November 2002, the Government of Canada enacted the Nuclear Fuel Waste Act (NFWA). Under the NFWA, the Nuclear Waste Management Organization (NWMO) was established to

consult with stakeholders, and to recommend an appropriate long-term management approach for nuclear fuel waste in Canada. Following three years of consultation, Adaptive Phased Management was recommended. The approach has the following characteristics:

- Ultimate centralized containment and isolation of used fuel in a DGR in a suitable rock formation, with a focus on the crystalline rock or sedimentary rock of the four nuclear provinces;
- Flexibility in the pace and manner of implementation through a phased decision-making process, supported by a program of continuous learning, research and development;
- Provision for an optional step in the implementation process involving shallow underground storage of used fuel at the central site prior to final placement in a DGR;
- Continuous monitoring of used fuel to support data collection and confirmation of safety and performance of the DGR; and
- Potential for retrievability of used fuel for an extended period, until such time as a future society decides on final closure, and appropriate form and duration of post-closure monitoring.

2.2 *Implementation phases*

In 2007, the Government of Canada accepted the NWMO recommendation for Adaptive Phased Management. The NWMO is now implementing Adaptive Phased Management and collaboratively developing with Canadians the process to site a deep geological repository for nuclear fuel waste. Adaptive Phased Management will proceed in phases. From a technical perspective, following the launch of the siting process, the initial phase will likely involve feasibility studies and preliminary investigations at potential sites in volunteer communities, followed by more detailed site investigations to confirm whether the candidate sites have the geological characteristics required to safely host a repository. Following selection of a preferred site and the necessary environmental assessment and licence approval process, an underground characterization facility (UCF) would be constructed and site-specific research and technology demonstration would be performed. During this period, in-situ characteristics of the site at repository depth would be obtained and the final design and safety assessments would be prepared prior to final construction and operation of the repository.

3 TECHNICAL ASPECTS OF A DEEP GEOLOGICAL REPOSITORY

3.1 *Technical host rock considerations*

The central facility for long-term used fuel management is to be located in a suitable rock formation such as crystalline rock or sedimentary rock. These two rock types cover large portions of several provinces and territories.

Since the 1980s, a limited number of Canadian studies have been undertaken on the potential for sedimentary rock as a host medium for a DGR (e.g. Mazurek, 2004). From a geoscientific perspective, sedimentary rock formations such as the Ordovician (age 470 to 430 million years) have low hydraulic conductivity, resulting in very slow movement of groundwater in the formations, with the migration of dissolved material dominated by diffusion. Furthermore, sedimentary formations comprising clay may be capable of self-sealing fractures and faults, and the clay minerals tend to retard migration of many dissolved minerals through a process of adsorption. Construction of a DGR for used fuel in sedimentary rock in Canada was determined to be feasible, and was estimated to cost about the same or less than a DGR constructed in crystalline rock (RWE-NUKEM 2004a, b).

Independent geoscientific studies suggest that Ordovician shales and limestones may provide a suitable environment to host a DGR for used fuel in Canada (NWMO 2005). Like the Canadian Shield granite, Ordovician sedimentary rock basins are naturally occurring geological formations characterized by long-term stability, relatively high rock strength, and low groundwater flow. Suitable horizons within these formations that occur at sufficient depth below ground surface, and lack mineral resources, are highly unlikely to be disturbed by erosion or accidental drilling. However, further research is required to prepare a safety case for a DGR. Also, an assessment of results from detailed site specific characterization activities obtained during the site investigation, site selection, and licensing phase would be required to confirm the technical suitability of any host rock formation for a DGR.

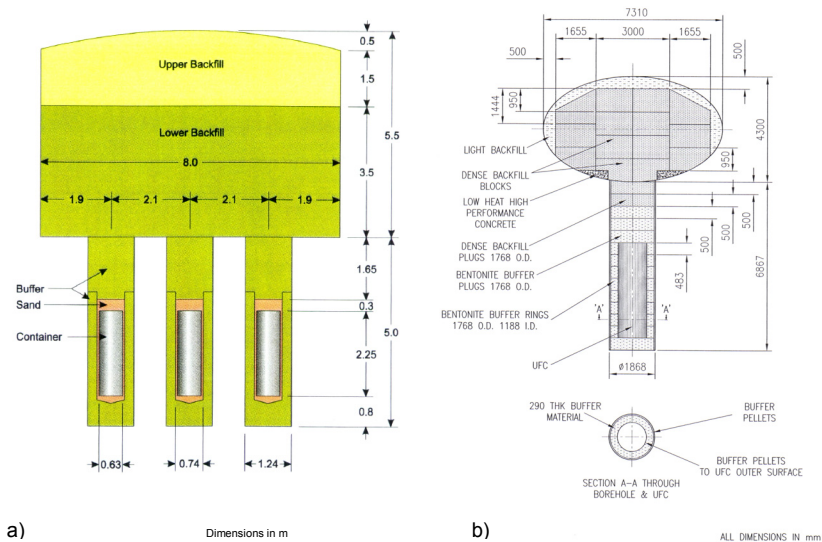

Figure 1. In-floor borehole placement concepts: a) original AECL design (AECL 1994), and b) modified design (RWE-NUKEM 2003) based on the KBS-3V concept.

3.2 Conceptual repository designs

A DGR will comprise a series of underground openings including shafts (and possibly ramps), access tunnels, placement rooms, and other excavations required for underground operations. Excavations will remain open during repository construction and operation, and will be sealed following placement of used fuel. Ground support may be used in the short-term to provide a safe working environment, but is planned to be removed during backfilling and sealing.

Some countries have selected a final DGR design for their deep repository (e.g. the KBS-3 design in Sweden). In Canada, several conceptual designs are still under consideration pending further engineering developments and site-specific information. These conceptual designs include:

- In-borehole placement designs involving deposition of used fuel containers (UFCs) in either vertical boreholes in the floor of horizontal placement rooms, or in horizontal boreholes drilled from access tunnels, lined with clay-based buffer materials.
- In-room placement designs involving deposition of UFCs in horizontal circular or non-circular placement rooms filled with clay-based buffer and backfill materials.

In each concept, the DGR would be located at a depth of about 500 m below ground surface in a suitable host rock formation. Two conceptual in-floor borehole placement concepts are shown in Figure 1 for illustrative purposes.

4 ROCK ENGINEERING ASPECTS OF REPOSITORY DEVELOPMENT

4.1 Previous studies

Rock engineering considerations and issues related to development of a DGR in crystalline rock have been investigated in Canada, Sweden, and other countries. Andersson et al. (2000) provide a summary of geoscientific suitability indicators and criteria for siting and site evaluation in Sweden, with particular emphasis on host rock requirements for a KBS-3 repository. Based on SKB's experience over many years of research and development, the report details required and preferred characteristics and conditions in the rock, and criteria to be used to identify potential candidate sites, and during site investigation at each candidate site. The reported requirements, preferences, and criteria provide the technical basis for SKB's site selection process and site investigations.

The results, and particularly the stipulated criteria, apply to a KBS-3 repository for used fuel, where the fuel is contained in copper canisters embedded in bentonite clay at a depth of 400 to 700 m in the Swedish crystalline basement. If the repository concept is changed or if new tech-

nical or scientific advances are made, certain requirements, preferences, or criteria may need to be revised. Andersson et al. (2000) emphasize that findings of the report cannot be used directly as a basis for siting other types of repositories, or in other geological settings.

Martin et al. (2001) synthesize important rock mechanics findings from the Canadian and Swedish research programs, and identify their relevance in assessing the stability of underground openings. The report draws heavily on published results from SKB's ZEDEX Experiment in Sweden (Olsson et al. 1996) and AECL's Mine-by Experiment in Canada (Read & Martin 1996), and incorporates examples from mining and tunneling to illustrate the application of these findings to underground excavations in general.

The report describes the role rock engineering can play in siting and constructing a KBS-3 repository. The key rock mechanics parameters to be determined in order to facilitate repository siting and construction in crystalline rock are identified. Possible construction issues associated with rock stability that may arise during excavation of underground openings of a KBS-3 repository are discussed. The report provides a convenient reference document for major rock mechanics issues to be addressed during siting, construction and closure of a nuclear waste repository in hard crystalline rock in Sweden.

Read & Chandler (2002) describe the Thermal-Mechanical Stability Studies (TMSS), a comprehensive multi-disciplinary research project conducted in Canada between 1996 and 2001. The authors describe the main objectives of excavation design for a nuclear waste repository as follows: 1) to create stable underground openings capable of withstanding the thermal-mechanical loading history expected over the lifetime of a repository, and 2) to minimize excavation damage. The goal of the TMSS was to develop a suite of engineering tools and techniques to facilitate design of stable repository excavations with minimal excavation damage.

The TMSS project advanced the state of knowledge in a number of areas including: numerical modeling of progressive failure and damage development around underground openings using the Particle Flow Code (PFC) and other micro-mechanical models; monitoring rock mass response to excavation using conventional instruments in conjunction with acoustic emission/microseismic (AE/MS) monitoring technology and methods; and characterizing rock properties and rock mass response under ambient and elevated temperature through specialized in situ and laboratory characterization and testing methods. The role of thermo-poroelasticity of the rock mass and pore pressure analyses in rock mass stability calculations were also assessed.

Read & Chandler (2002) summarize findings from the TMSS in the context of DGR rock mechanics studies, and assess the state-of-the-art in repository excavation design tools and capabilities. They also define a systematic design approach that integrates characterization, monitoring, and numerical modeling tools and capabilities into an engineering system for back analysis and forward prediction of short- and long-term rock mass responses, and associated changes in material properties. Although the focus of the report is a DGR in crystalline rock in Canada, many of the findings are applicable to other host rock environments and applications.

4.2 *Siting*

The main roles of rock engineering in technical siting of a DGR in sedimentary rock are: to characterize the surface and subsurface rock mass in terms of the distribution of major geological features and lithostratigraphic units; to determine the characteristics, properties, and conditions of the rock mass that affect its response to DGR development; to use the information to conduct engineering scoping analyses of DGR design concepts; and to compare the collected information and analysis results against selection and exclusion criteria. The primary rock engineering requirements to complete these steps are as follows:

- Geological framework – develop a clear understanding of the surficial geology, lithostratigraphy, and structural geology of potential candidate sites. This requires compilation of information into a database from which to develop 3D models of surface and subsurface geological conditions, specifically a digital elevation model showing surface features, a lithostratigraphic model showing distribution of rock types, and a structural geology model showing distribution of faults/fracture zones.
- Rock properties – conduct laboratory and in situ testing to develop a database of rock mechanical, thermal, hydraulic and chemical properties for each of the major lithostratigraphic

layers for use in site screening and selection. Identify possible ore or mineral horizons that may exclude the site from further consideration.

- Fracture and discontinuity characteristics – determine characteristics and properties of fractures and discontinuities in each of the lithostratigraphic units, and of the major fracture zones and faults identified during site investigation. This includes hydraulic, thermal, mechanical and chemical characteristics and properties.
- In situ conditions – determine profiles of in situ stress, pore pressure, and temperature with depth for use in scoping analyses. Groundwater chemistry (particularly salinity) should be measured to ensure proper groundwater density is used in analysis, and to compare to exclusion criteria. Determine seismic/tectonic history of each site, and expected seismic conditions and associated parameters for dynamic analysis.
- Rock mass classification – classify the rock mass conditions using standard rock mass classification systems to assess tunneling quality and possible support requirements to maintain stability of underground openings.
- Climatic conditions – determine the climatic conditions for each site based on climate records and forecasting of possible climate change effects. Determine the glaciation history for each site and identify possible glaciation-related features such as reactivated faults, isostatic rebound, and erosion potential.
- Engineering scoping analysis – conduct scoping analyses using simplified models to determine feasibility of constructing a DGR at each potential candidate site. The results from these analyses are intended to provide part of the basis for site selection or exclusion. Engineering assessments are updated as new information is collected through subsequent activities, such as development of the UCF.

4.3 Design

The engineering design process can be broken into conceptual, preliminary, and detailed engineering. The successive design stages require increasingly accurate information related to in situ conditions and properties. Consequently, ongoing site characterization is an integral element of the design process to build on the information gathered during the site selection and investigation process.

Much of this characterization work is conducted as part of the UCF development and operation, or is undertaken during construction. Figure 2 shows the HADES Underground Research Facility in Mol, Belgium, an example of a UCF where in situ tests in sedimentary rock (Boom clay) have been conducted. The selection (or development), testing, and qualification of monitoring instrumentation and approaches, and their application to acquire baseline data and measurements during excavation and testing activities, is a second element of the design process. In conjunction with ongoing site characterization and monitoring, the selection (or development), testing, and qualification of analytical tools and approaches is a third element of the design process. These analytical tools/approaches derive their inputs from the collected site characterization and monitoring data.



Figure 2. HADES Underground Research Facility, Mol, Belgium (R. Read).

The role of rock engineering in these various design stages involves several activities:

- Characterization - plan and conduct controlled laboratory and in situ tests, experiments, and demonstrations to determine or confirm specific aspects of material and component behaviour and/or performance, and to provide data for model calibration/validation. The development of damage in the near-field rock mass is a specific rock mechanics issue requiring investigation. Single- and multi-component tests, experiments, and demonstrations are required to ensure material behaviour and interactions between system components are understood.
- Monitoring - select and deploy instrumentation to monitor component and system performance during construction and for tests, experiments, and demonstrations in the UCF environment. Longevity and reliability of instrumentation are two important design considerations.
- Analysis - develop criteria and correlations, and associated application methodologies, that bridge the gap between laboratory and in situ data, particularly with respect to long-term rock strength and scale effects. This aspect of rock engineering is particularly challenging. Recent work by Diederichs (2007) has advanced findings of the TMSS (Read & Chandler 2002) for crystalline rock. A similar line of reasoning is required to ensure material behaviour of sedimentary rock is treated consistently at both laboratory and field scale in numerical models.
- Numerical modeling - select (or develop), test and qualify design tools such as numerical modeling codes and analytical methods, using results from controlled laboratory and in situ experiments and tests to validate the tools. Qualification of design tools is essential to build confidence in their application to DGR design.
- Excavation design - refine the repository layout and excavation designs to meet design specifications, using detailed site characterization data obtained from in situ characterization activities and monitoring. This would involve room and pillar dimensioning to ensure long-term stability of the repository, as well as excavation sequencing and selection of suitable excavation methods and equipment.
- Ground support design - design and implement ground support systems as required to maintain stability of underground openings for the duration of the construction stage, and beyond into the long-term monitoring stage. This activity carries into construction.
- Sealing system design - design sealing systems compatible with in situ rock mass conditions to ensure containment of radionuclides for the requisite containment period. Of particular interest are the interfaces between the clay- and concrete-based sealing components and the rock mass, including design of rock cutoff keys (Martin et al. 1996, Read & Dixon 2003). This activity carries into construction.
- Performance verification - verify overall system performance to support a decision to close the repository. This activity carries into post-construction.

4.4 *Construction and operation*

The primary role of rock engineering during construction/operations is to conduct ongoing characterization of DGR excavations, update the geosphere model and rock mass classification, and adjust the DGR design and construction execution plan accordingly. Back analysis of observed behaviours and measured responses is an integral part of design refinement. Active involvement in the selection/design, implementation, and monitoring of excavation methods, ground support, and sealing systems is also a priority. The design and implementation of appropriate monitoring systems, and ongoing management and analysis of monitoring data, is an important function at this stage of DGR development. Rock engineering in the construction and operation of a DGR involves several activities:

- Excavation - adapt DGR design specifications into a construction execution plan in conjunction with other disciplines (e.g. mining engineering, civil engineering, and construction). This involves evaluating different excavation methods and equipment, estimating productivity and equipment wear through specialized in situ and laboratory testing (tool-rock interaction studies), and analyzing potential effects of different excavation schedules and staging/sequencing options to minimize adverse effects on the rock mass around underground openings. It also entails developing procedures for incorporating results from excavation characterization into design modifications during construction.
- Ground support – selection, design, implementation and monitoring of ground support systems is required to ensure worker safety during construction, and to preserve the integrity of

the rock mass during construction and operation of the DGR. Some sedimentary rock types may pose particular challenges in terms of avoiding degradation effects on exposed rock surfaces, and ensuring long-term performance of bolting systems. Gas generation of metal bolting systems has been raised in previous conceptual designs as a potential issue, and may require additional study in the context of gas migration in sedimentary rock.

- Characterization – conduct ongoing characterization of conditions and properties in excavations using techniques developed for the UCF, and update the geosphere model and rock mass classification of the excavations. This process is iterative and involves improving the understanding of rock mass conditions over the construction period. Back analysis of observed conditions also allows for improvements to predictive tools and techniques.
- Design modification – update the design of specific repository panels and/or individual placement rooms based on results of excavation characterization conducted immediately following placement room excavation. This process involves conducting confirmatory analyses of potential effects using numerical tools developed for design analysis. This process could involve changes to the arrangement of panels and rooms to avoid potentially undesirable geological features, or changes to the positioning or spacing of placed UFCs in a particular room to avoid intersecting fractures. These types of modifications require a well-defined decision protocol to ensure design changes are not made on an ad hoc basis, and that as-built conditions are well documented.
- Sealing systems – in conjunction with other disciplines, develop detailed designs for sealing systems (including backfill, bulkheads, and grouting) and assess their potential interactions with the rock mass as the basis for establishing monitoring systems to gauge performance. In particular, swelling pressure exerted by the backfill on the rock mass is an important design element to ensure long-term stability and integrity of the near-field rock mass. Likewise, the integrity and effectiveness of sealing elements such as bulkheads and grouting of the rock-concrete interface, and their interaction with the rock mass, are important to long-term performance and safety (Figure 3). Remedial grouting of fracture zones and other potential hydraulic flowpaths may require further study in the context of specific sedimentary rock types to fully understand potential chemical and mechanical interactions.
- Monitoring – monitor the rock mass during excavation activities and over the course of the construction and operations period to identify possible development of damage around openings. Remote monitoring using AE and MS sensors is considered a preferred non-intrusive method to conduct monitoring of placement rooms. In addition, other strategically placed instruments are required to measure the performance of sealing systems. These instruments could include sensors to monitor displacement, temperature, pressure, and humidity, for example. Specific instrumentation requirements would be determined on the basis of rock mass response observed during development of the UCF. Ongoing management and analysis of monitoring data is also required.



Figure 3. Pouring a keyed concrete bulkhead for the Tunnel Sealing Experiment in Canada (Read 2008).

